

Linear shower drainage channel made of polypropylene with a stainless-steel cover

DURAL

Outlet and odour trap:

One of the most important prerequisites for optimum operation of the channel is the technical solution employed for the outlet and odour trap. Since the outlet is integrated in the body of the channel, the usual attachment of a separate outlet bowl can be dispensed with. The outlet bowl is designed to allow easy and thorough cleaning through to the discharge pipe and to provide sufficient flow capacity. The odour trap in the outlet bowl can be completely disassembled and is fitted with two connected discharge chambers and a flap valve to prevent the odour trap from drying out. The odour trap can be removed easily for cleaning. According to the drainage regulations, the DN 40 discharge pipe from the outlet bowl should be connected to the house drainage system via a DN 50 PVC drainage pipe. The transition from DN 40 to DN 50 can be achieved using a suitable PVC adapter piece. The drainage pipe should have a gradient of approximately 1 %.

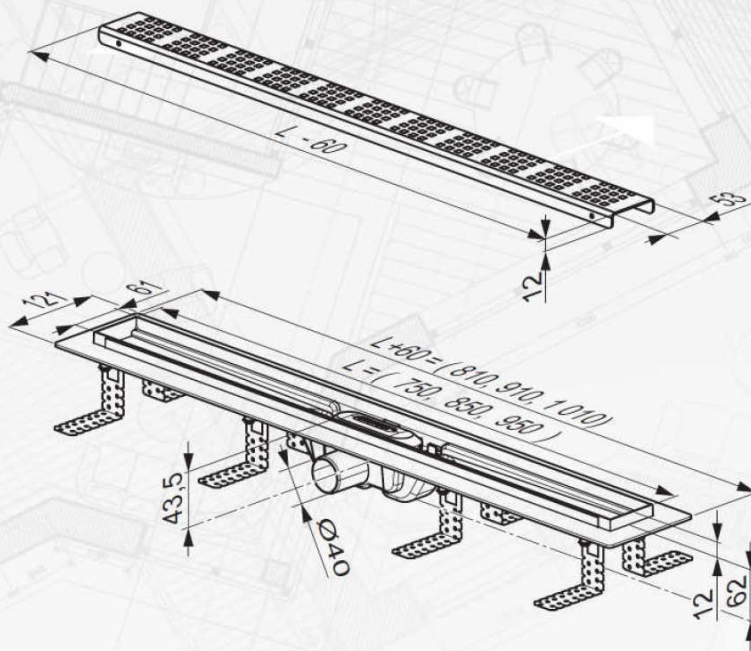
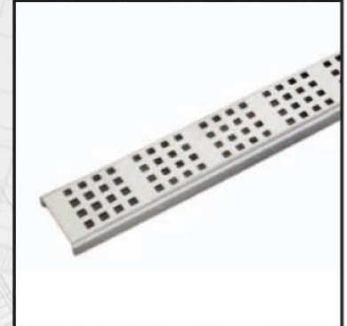

PRODUCT DATA:

MATERIAL:	Drainage channel = Polypropylene Grate = Stainless steel (1.4301)
MATERIAL THICKNESS:	1,5 mm (designer grate)
LOAD CLASSIFICATION:	H 1,5 (up to 150 kg)
INSTALLATION HEIGHT:	> 62 mm
PIPE CONNECTION:	DN 40 with odour seal
DRAINAGE CAPACITY:	> 30 l/min.
FORMATS (A, B, C):	EL 800 (810 x 121) – Visible dimensions 750 x 61 mm EL 900 (910 x 121) – Visible dimensions 850 x 61 mm EL 1000 (1010 x 121) – Visible dimensions 950 x 61 mm

προφoρμα

ΦΙΛΙΠΠΙΔΗΣ
ΕΙΔΙΚΑ ΔΟΜΙΚΑ ΥΛΙΚΑ Α.Ε.

ΕΜΠΟΡΙΚΟ ΚΕΝΤΡΟ EUROTECH
13ο χλμ. Θεσσαλονίκης-Μυθωνίων, Τ.Κ. 570 01 ΘΕΡΜΗ - Τ.Θ. 69364
ΤΗΛ.: 2310.473.978, 2310.473.778 - FAX: 2310.473.161
e-mail: proforma@otenet.gr

